

ON-2000

Power by Perkins

4016TAG2A

Prime power: 1600KW/2000KVA

Standby power: 1800KW/2250KVA

GENERATING POWER SOLUTIONS

Increased availability for new operations

Reliable, robust and versatile generator.
Ready to deliver power for a next job.

Increased uptime during operations

Once installed on the end-user-site, the generator will be ready to run: "peace of mind" operation.

Reduced transport and installation costs

The compact and robust design with integrated transport features enables faster and safer transport and installation.

Reduced service & maintenance costs

Longer service intervals.
Quicker and more efficient service jobs.

Premium resale value

Designed and built to last.

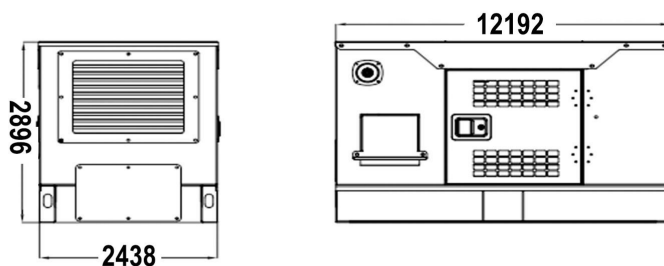

DIMENSION		OPEN TYPE	SILENT TYPE
Length (L)	mm	5795	12192
Width (W)	mm	2200	2438
Height (H)	mm	2565	2896
Dry weight	kg	11500	18200
Fuel tank	L	TBD	2000

ONEWPOWER

WWW.ONEWPOWER.COM

Technical Data

Model ON-2000

Rated prime power	KW	1600
Rated standard power	KW	1800
Rated voltage line to line	V	380~415
Maximun sound level	dB(@7m)	≤72

Engine

Model		4016TAG2A
Aspiration		Turbocharged
Fuel system		mechanical pump
No. cylinders		16
Displacement	Liquid	61.123
Bore*Stroke	mm	160*190
Compression ratio		13.6:1 nominal
Rated speed	r/min	1500
Rated net power(with fan)	Kw	1800
Governor type		Electronical

Exhaust system

Exhaust gas flow		387 m³/min
Exhaust gas temp	° F (° C)	<493
Max back pressure		673 mm H2O

Aspiration system

Max inlet pressure	kPa	≤3.5
Combustion volume	L/s	/
Air flow		TBD

Fuel system

100% load(Prime power)	L/h	434
75% load(Prime power)	L/h	316
50% load(Prime power)	L/h	210
Fuel tank capacity	L	2000

Lubrication system

Oil capacity	L	214
Oil consumption	g/kwh	28.3
Oil pressure	kPa	10
(continuous operation)		

Cooling system

Coolant capacity	L	316
Thermostat operation range	°C	76-88
Max water temperature	°C	98

Alternator

Model		ON-2000
Phase		3
Voltage	V	380~415
Bearing		1
Power factor		0.8
Frequency	Hz	50
Prime power	KW	1600
Exciter Type		Brushless, self-excitation
Voltage regulation	%	±1.0
Protection Grade		IP 23
Insulation grade		H/H
Altitude	m	≤1000

Controller

Model

Protective functions:

- Low oil pressure
- High water temperature
- High/low voltage
- High Engine Temperature and Overspeed.
- Voltage regulator frequency regulator
- Emergency stop
- Start failure



Control Module Options



- Auto generator control module
- Control module with "Three Remote Control" functions
- ATS auto load transfer screen
- Synchronising control modules
- Power output cabinet

Standard features

- Engine
- Radiator 50°C max, fans are driven by belt
- 24V charge alternator
- Alternator: single bearing alternator IP23, insulation class H/H
- Standard auto control system
- One set of air filter, fuel filter, oil filter
- Main line circuit breaker/MCCB
- Base fuel tank
- Two 24V batteries, rac and cable
- Exhaust system(Ripple flex exhaust pipe, exhaust siphon, flange, muffler)
- User manual

Options

- Battery charge
- Engine heater
- Alternator heater
- PMG
- Water oil separator
- Daily fuel tank
- Remote control panel
- Automatic transfer switch/ATS
- Switch box
- Standard: ● Options: ○

Warranty

CUMMINS ENGINE

12 months from date of purchase and 1000 hours.

Generator

12 months from date of purchase or 1000 hours (whichever occurs first).

Dimensions

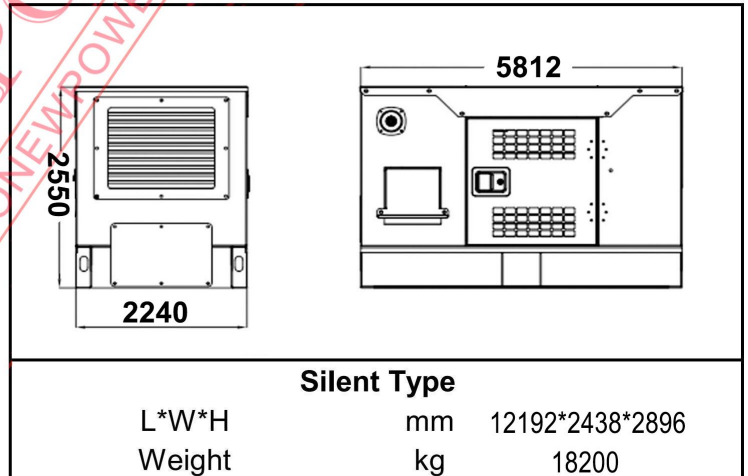
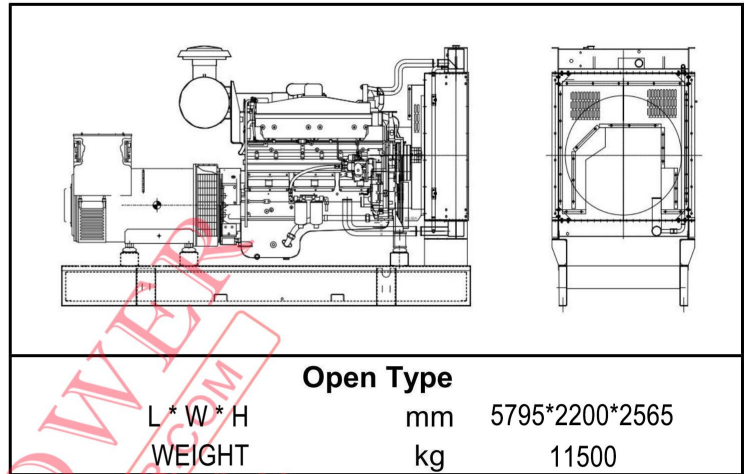

ONEWPOWER

ADD: NO . 1 0 7 XIYUAN ROAD , JINAN DISTRICT, FUZHOU CITY, FUJIAN, CHINA

Phone: 15980204507 E-mail: jina@onewpower.com

WWW.ONEWPOWER.COM

